

Verandering zonder Compromissen

PAC als Fundament
van Betrouwbaarheid

8 april 2026





Digital Substation of the Future (DSofF)

Dr. Alex Ştefanov

Director CRoF, Associate Professor, Chartered Engineer
Themadag CIGRE B5



April 8, 2026

About Me / Bio

- **Associate Professor** at TU Delft since May 2019
 - Cyber security of power grids (transmission, distribution & grid edge)
 - Cyber-physical system resiliency, cyber resilience
 - Control Room of the Future (CRoF) and next generation grid operation
- **Senior Engineer** at NovoGrid in Dublin, Ireland: 2018 - 2019
- **Professional Engineer** at ESB Networks (Irish Distribution System Operator): 2015 - 2018
 - Future Networks, Operations
- **Chartered Engineer** (CEng MIEI), Institution of Engineers of Ireland



Why Control Room of the Future (CRoF) & Digital Substation of the Future (DSoF)?

- Energy transition: decarbonisation, decentralisation and digitalisation
- Change the way we operate power grids (T&D systems)

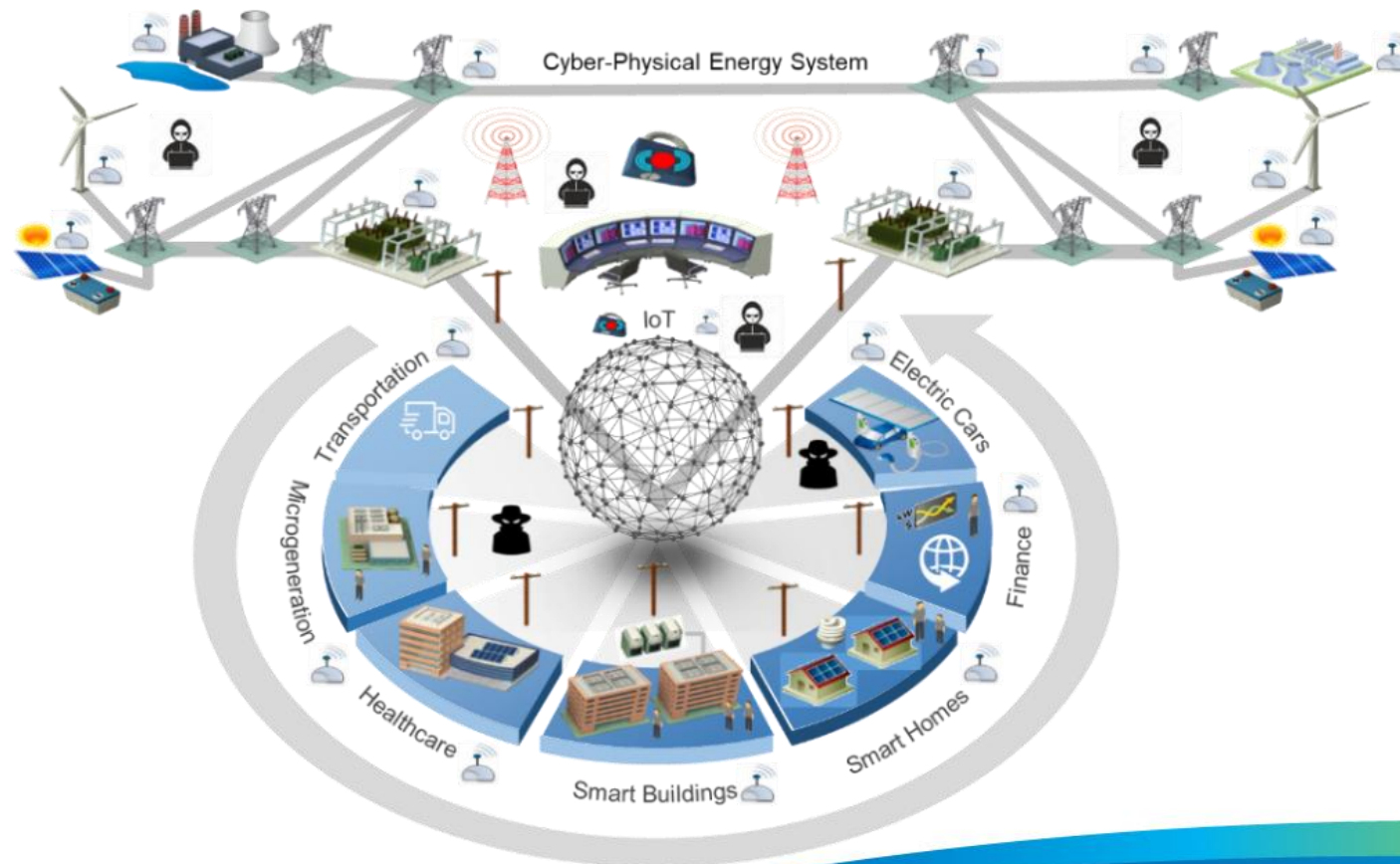

Control Room of the Future (CRoF) Vision



Control Room of the Future (CRoF) Technology Centre at TU Delft

Director: Dr Alex Stefanov, e-mail: A.I.Stefanov@tudelft.nl

● Vision

- Future power grid is intelligent (AI), resilient and cyber secure

● Facility for Research, Development & Demonstration

- CRoF is unique, future-ready and multi-domain experimental setup
 - ✓ Neutral ground for power grid operators (TSOs, DSOs) & vendors
 - ✓ Hub for future power grid technologies

● Research

- Intelligent power system operations
 - ✓ Future control of power systems
 - ✓ **Cyber security**
 - ✓ Digital twins
 - ✓ Artificially intelligent assistants
 - ✓ **Operational & cyber resilience**

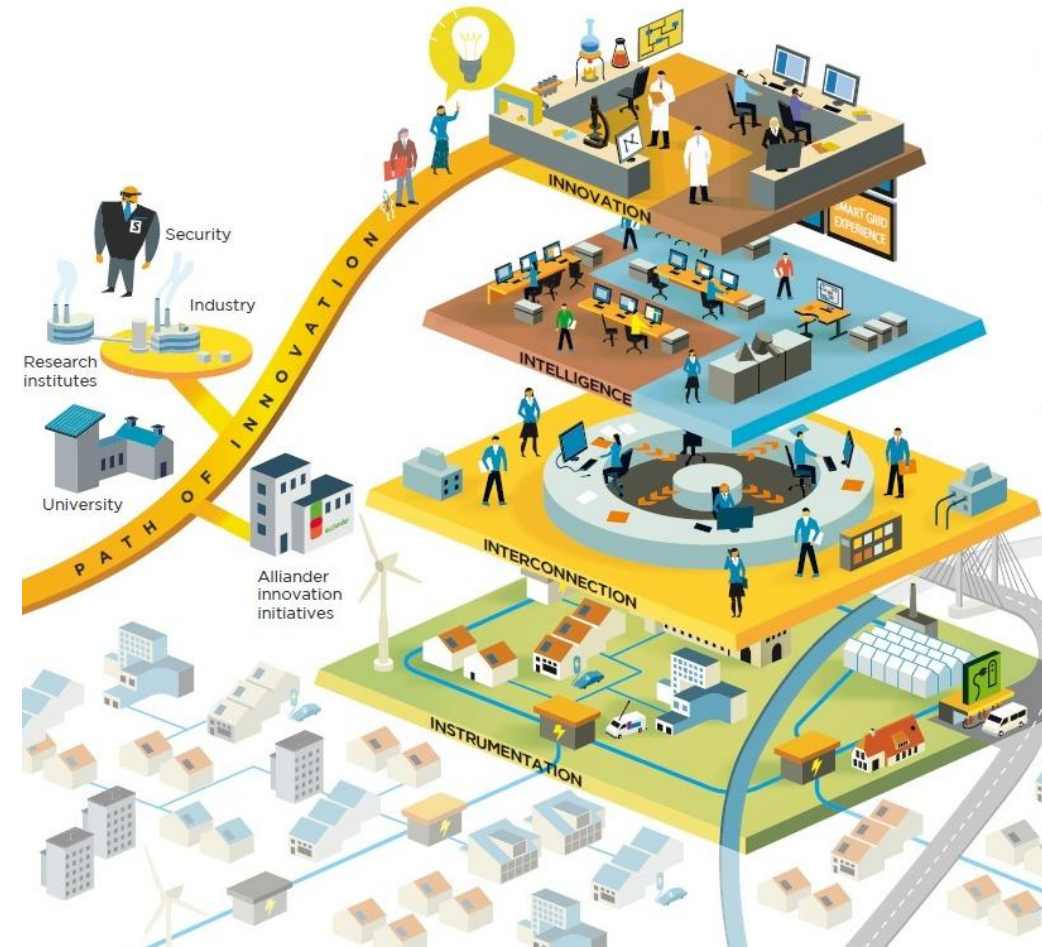

Source: alliander.com

Control Room of the Future (CRoF) Technology Centre at TU Delft

Director: Dr Alex Stefanov, e-mail: A.I.Stefanov@tudelft.nl



Control Room of the Future (CRoF) Technology Centre at TU Delft

Director: Dr Alex Stefanov, e-mail: A.I.Stefanov@tudelft.nl



Digital Substation of the Future (DSoF) at TU Delft: ESTELAR Project

Director: Dr Alex Ștefanov, e-mail: A.I.Stefanov@tudelft.nl



TU Delft Digital Substation (150 kV / 10 kV)



TSO/DSO 150 kV / 10 kV SLD - Digital Substation & RTDS

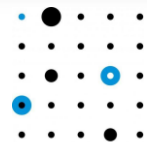
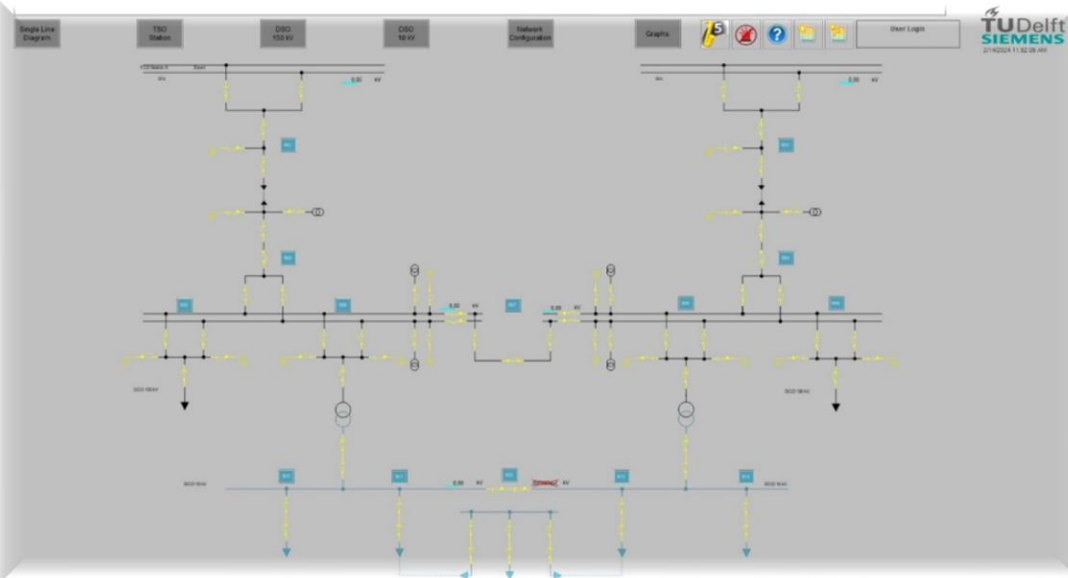

ENCS

DIGITAL SUBSTATION OF THE FUTURE (DSOF)

Next Generation Substation Automation

- Digital Twins & PAC vs. vPAC
- Cloud Solutions & Edge Computing
- Cyber Security & Cyber Resilience

Meer weten?

Contact
TU Delft, Alex Ștefanov, a.i.stefanov@tudelft.nl
Siemens, Corné de Hoogh, corne.de-hoogh@siemens.com

Digital Substation of the Future (DSoF) at TU Delft: ESTELAR Project

Director: Dr Alex Stefanov, e-mail: A.I.Stefanov@tudelft.nl



TU Delft Digital Substation (150 kV / 10 kV)

TU Delft Real-Time Digital Simulator (RTDS)

TSO/DSO 150 kV / 10 kV SLD - Digital Substation & RTDS

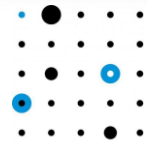
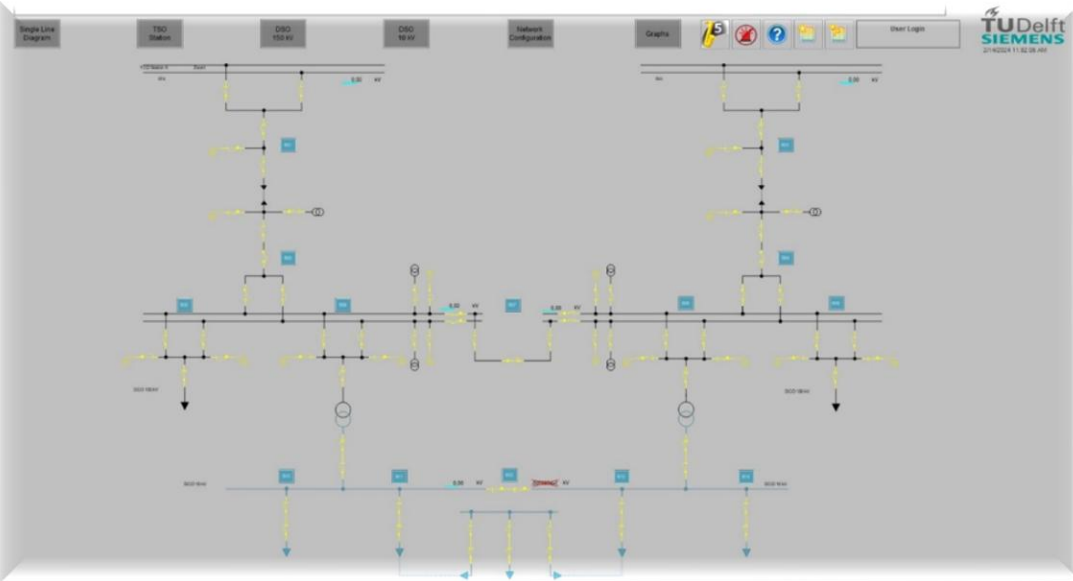

ENCS

ESTELAR Digital Substation of the Future: PAC to vPAC

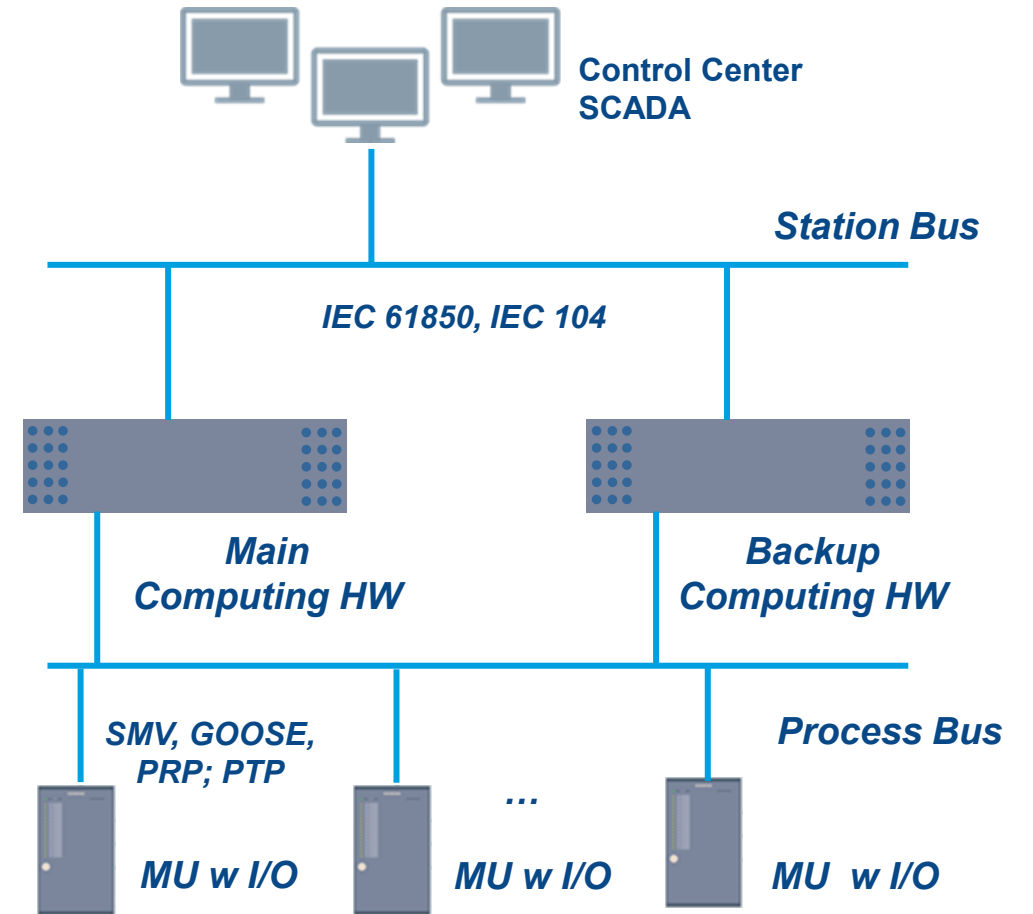
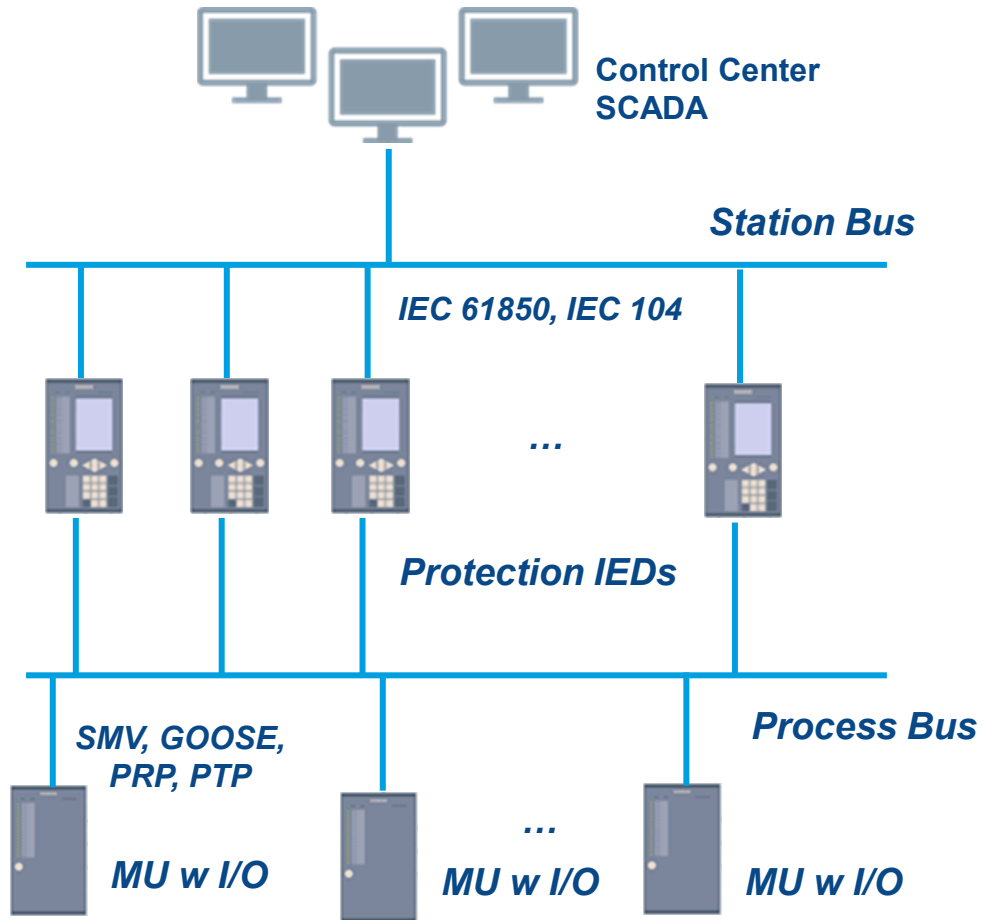

ESTELAR Digital Substation of the Future: PAC to vPAC

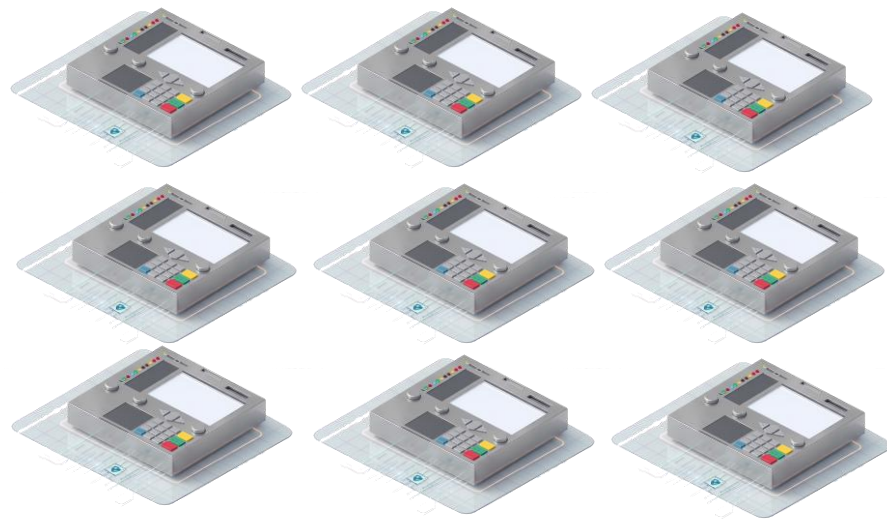

60+
Protection relays

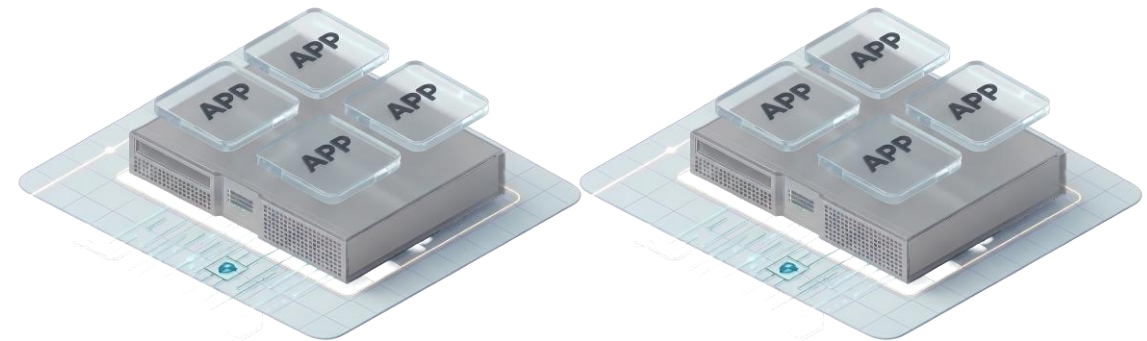

Main

Backup

2
Centralized Protection, Automation & Control
computing HW

ESTELAR Virtual Protection, Automation & Control

- Substation automation systems
 - Power quality, fault recording, AI, etc.
- HMI with substation-wide visibility
- vPAC software
 - All protection bays
 - Substation core system
- Linux with real-time kernel
- Independent hardware IEC61850 certified

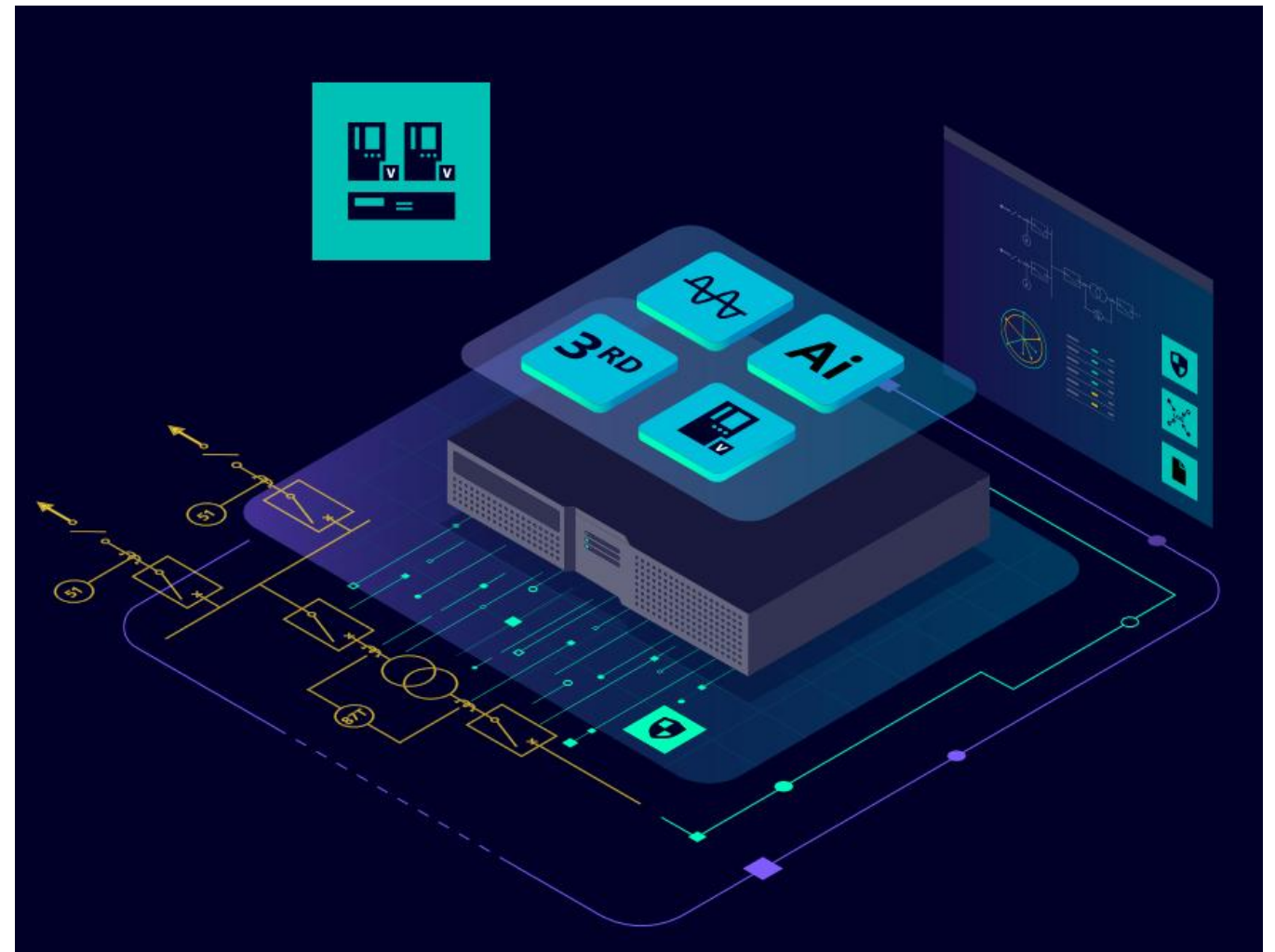

ESTELAR Virtual Protection, Automation & Control

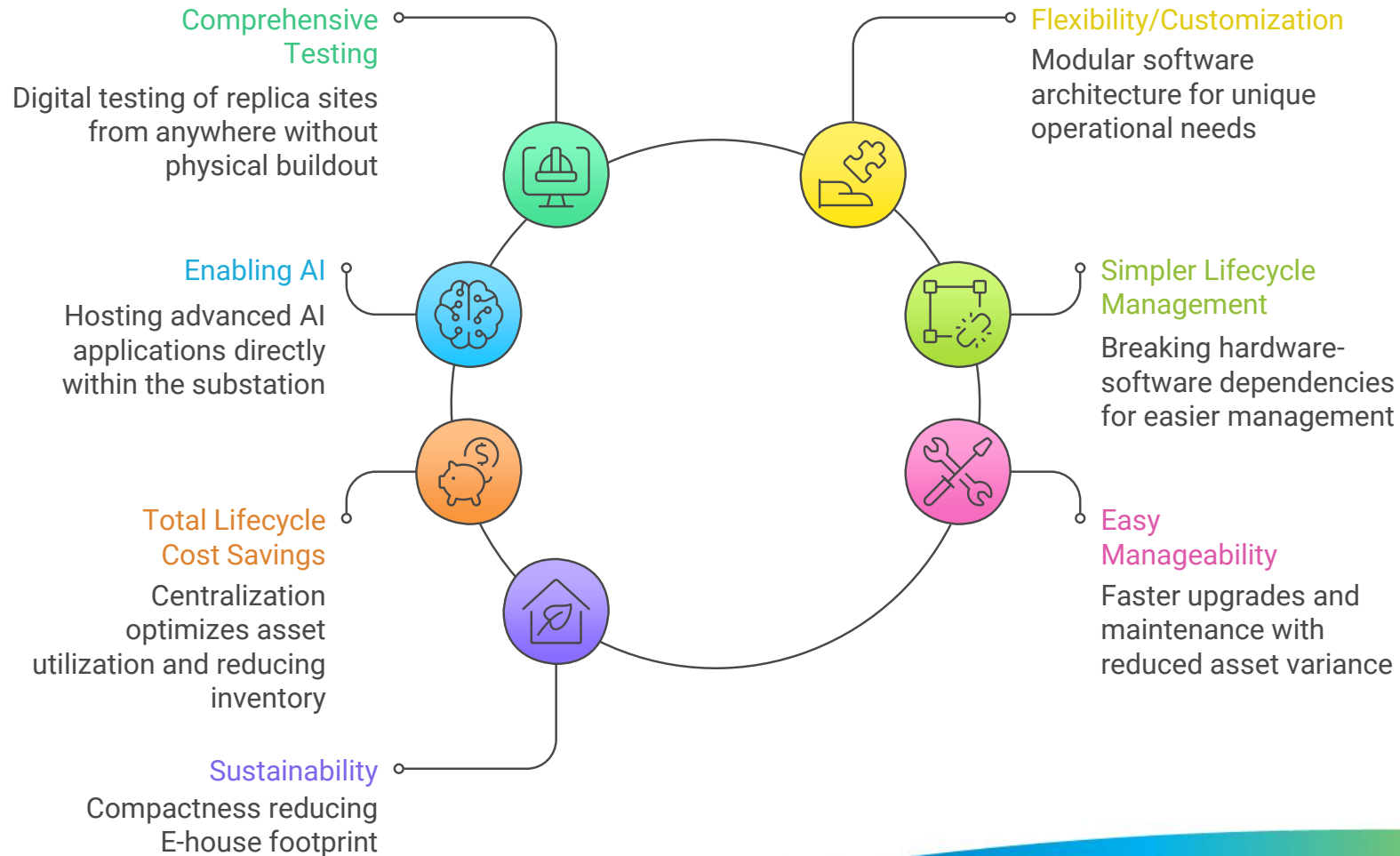

Virtual Protection, Automation & Control

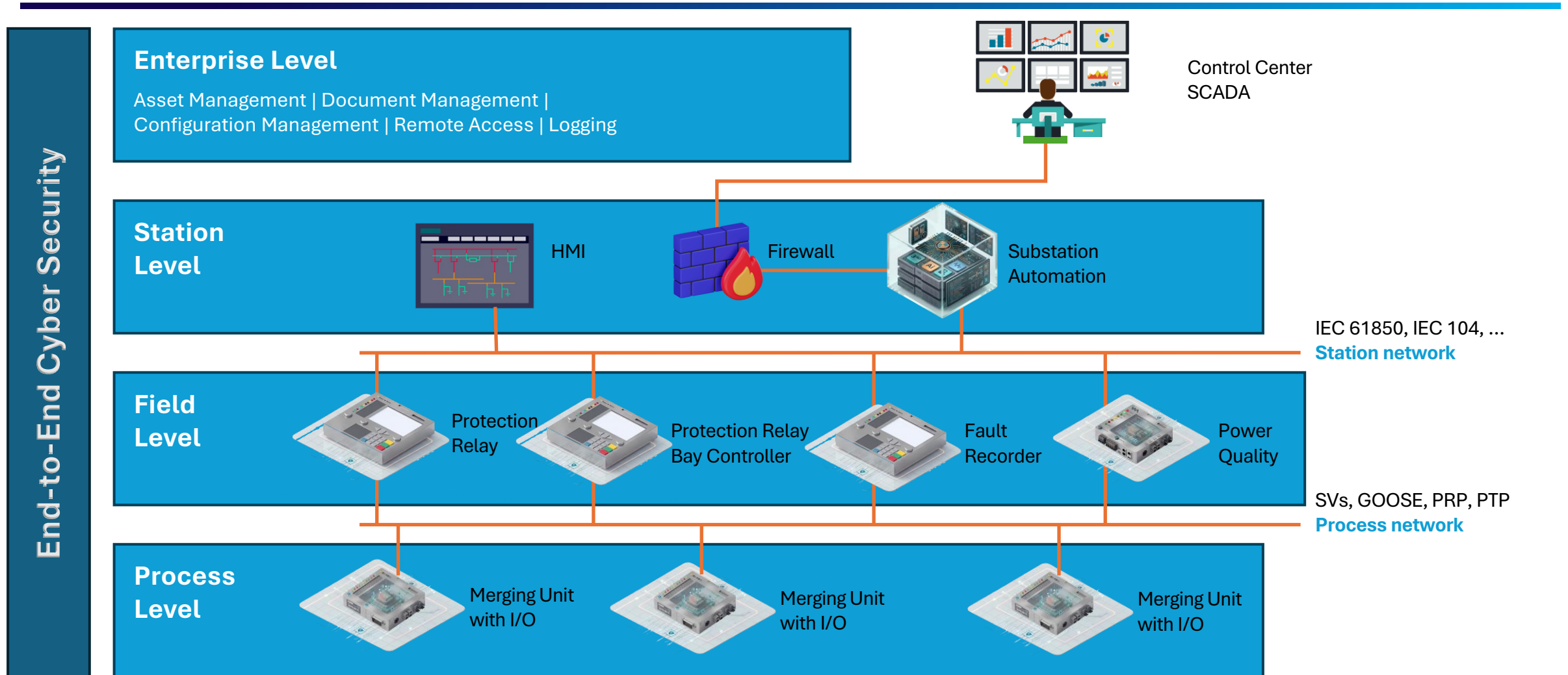

ESTELAR Virtual Protection, Automation & Control

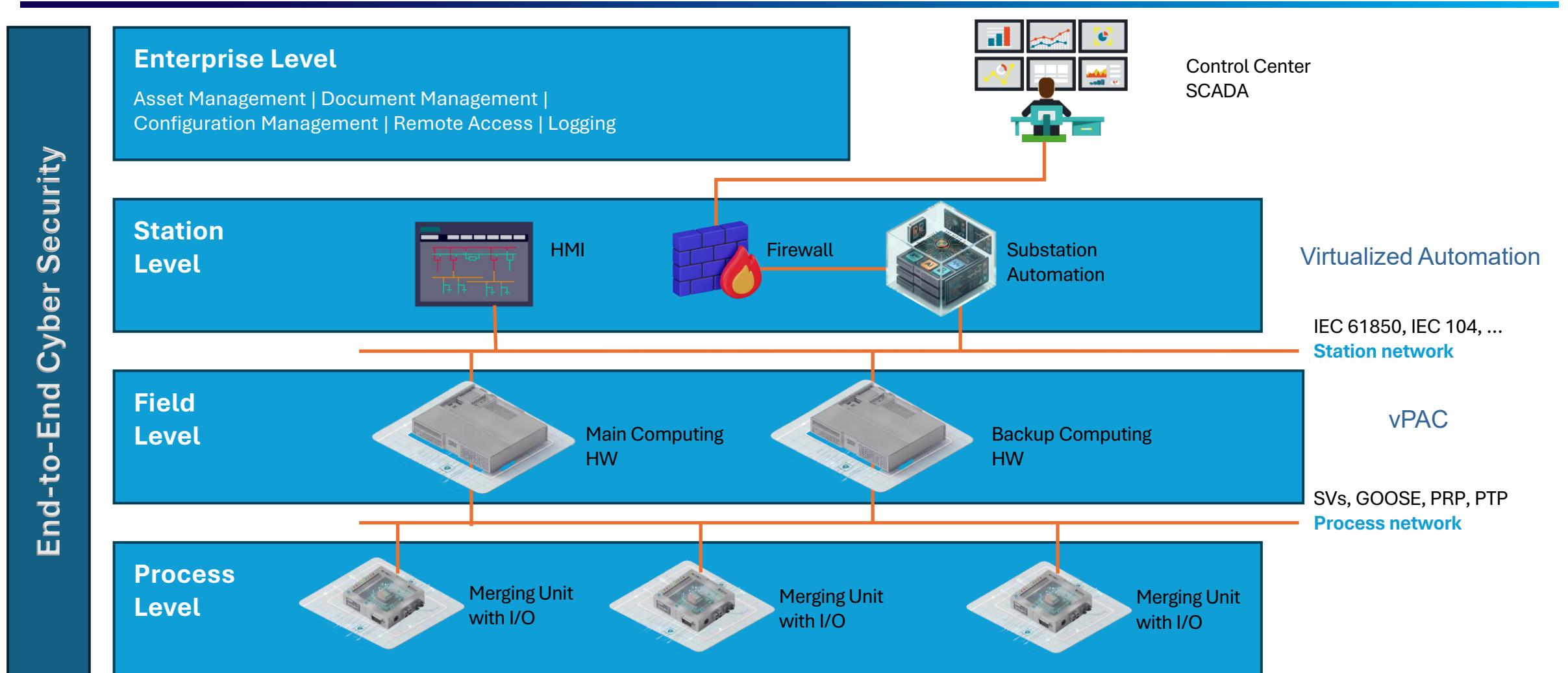

ESTELAR Cyber Security of Software-Defined Protection & Control

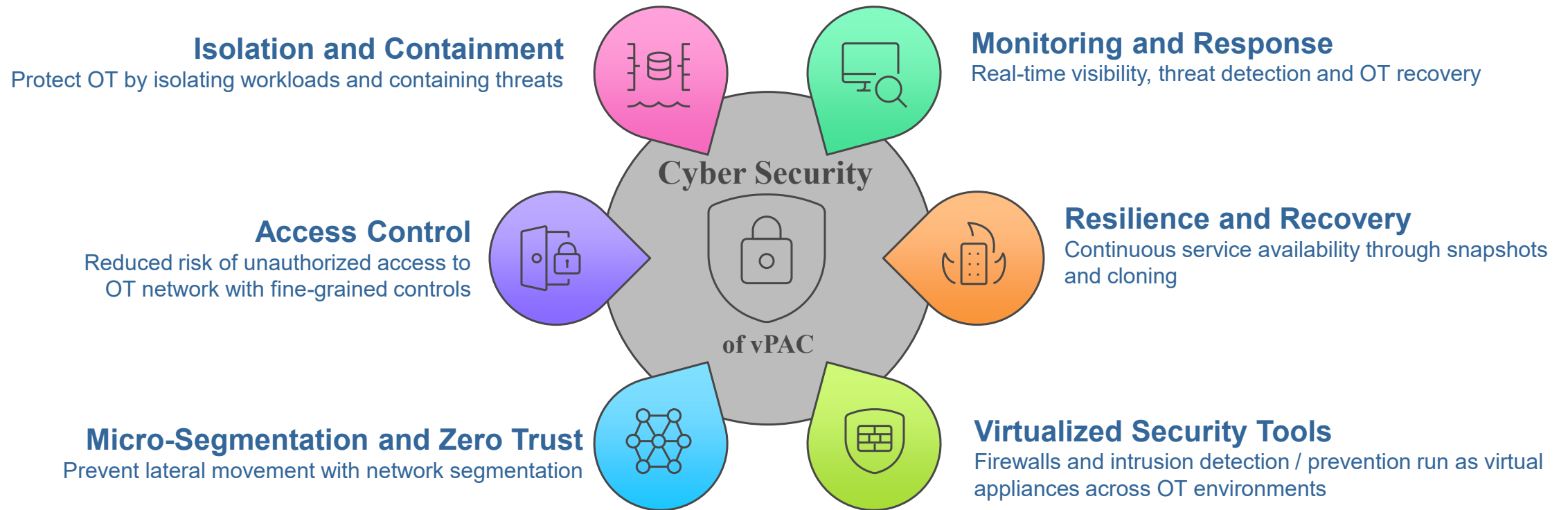

Digital Substation of the Future at TU Delft

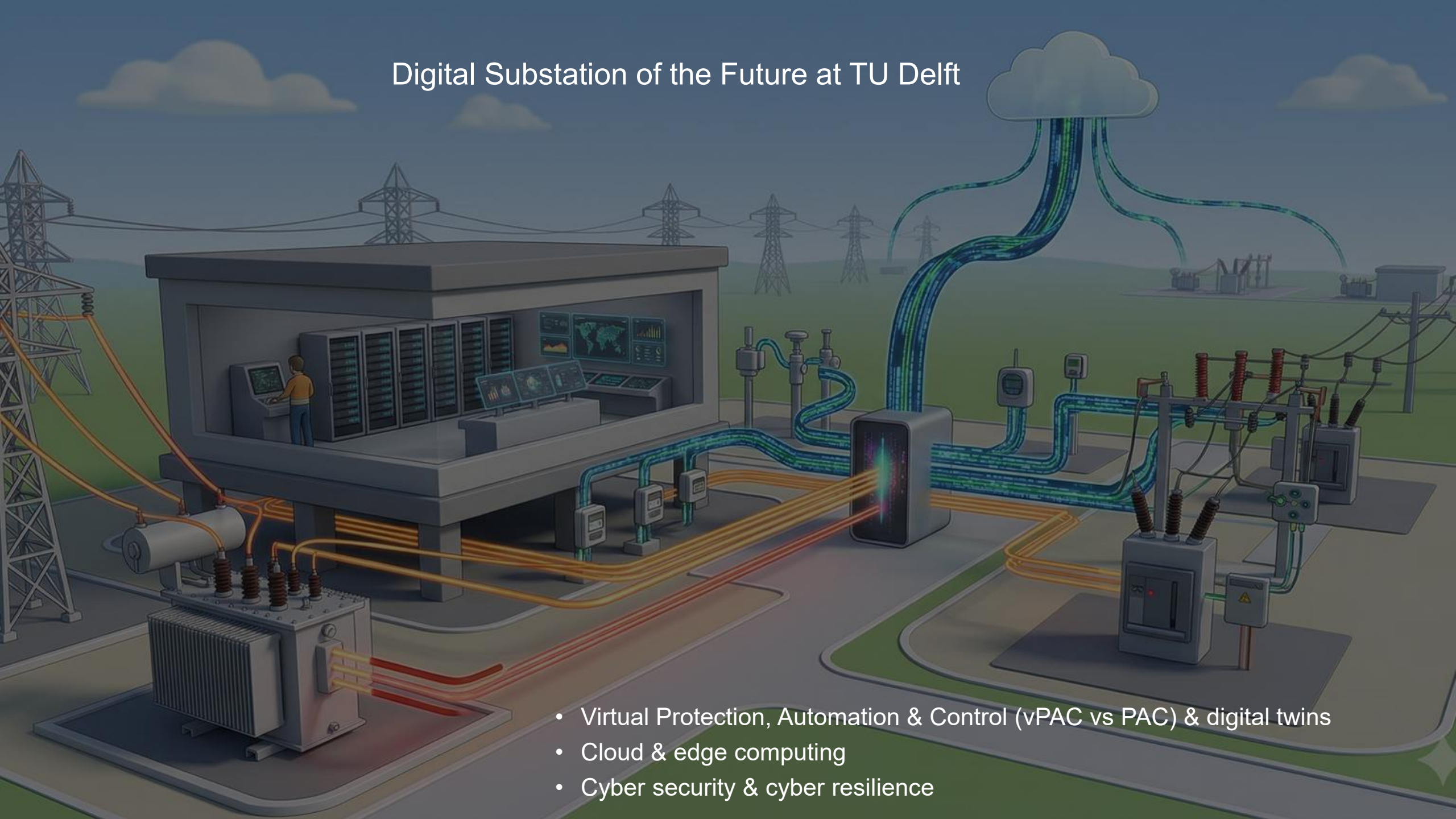

- Virtual Protection, Automation & Control (vPAC vs PAC) & digital twins
- Cloud & edge computing
- Cyber security & cyber resilience

Thank You!



Dr. Alex Ştefanov

Associate Professor, Chartered Engineer (CEng MIEI)

Email: A.I.Stefanov@tudelft.nl

Cyber Resilient Power Grids ([LinkedIn](#))

Control Room of the Future ([LinkedIn](#))

Intelligent Electrical Power Grids, EEMCS, **TU Delft**
Mekelweg 4, 2628 CD Delft, The Netherlands



Estelar

THANK YOU!

Funded by the European Union under Grant Agreement 101192574. Views and opinions expressed are those of the author(s) only and do not necessarily reflect those of the European Union or CINEA. Neither the European Union nor the granting authority can be held responsible for them.



**Funded by
the European Union**